

PROCEDURE

This product must be installed in accordance with the applicable installation code by a person familiar with the construction and operation of the product and the hazards involved. Do not install insulation within 3" of fixture sides or wiring compartment, nor above fixture in such a manner to entrap heat.

1. Take the 3 wires black, white, ground through the centered hole. Mount the round mounting plate on the junction box at the ceiling.
2. Connect the two input leads with the two driver wires . Take care of polarity (black/black) (white/white). ATTENTION: Carefully, place all the wiring into the junction box.
3. Fit the Piper lamp on the round mounting plate. Screw the two Allen bolts (1.5 mm) on the side.

1.

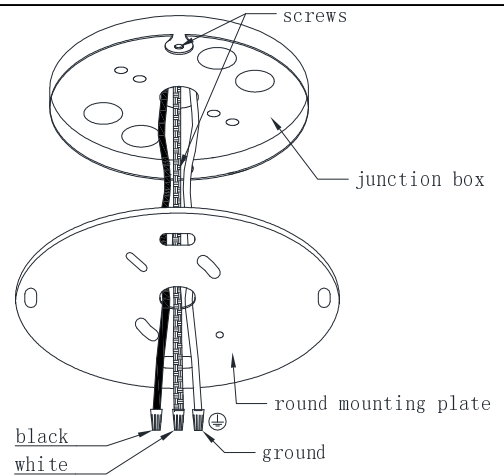

2.

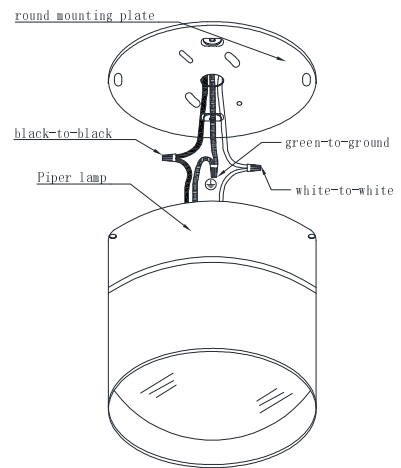

3.

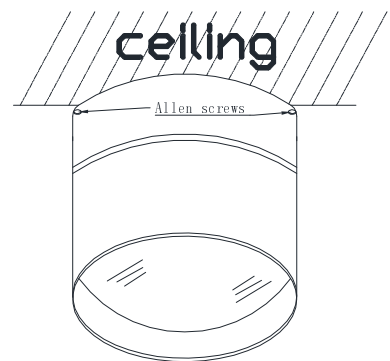

- Necessary installation equipment and screws:

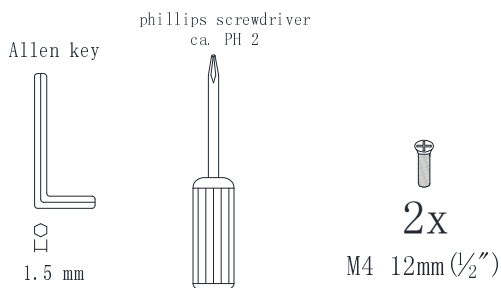

- **Damp Location Listed**
- **CSAus Certified**

IMPORTANT SAFETY INSTRUCTIONS:

- READ all the instructions before installation. Save instructions for later use.
- MIN 60°C SUPPLY CONDUCTORS.
- Turn off power at fuse or circuit breaker box before installation or before doing any maintenance work.
- Product must be mounted in locations and at heights and in manner consistent with its intended use, and in compliance with National Electric Code and local codes. Use of accessory equipment is not recommended.
- Installing contrary to instructions may cause unsafe conditions.
- Warning: Risk of fire. Consult a qualified electrician before installation.
- To avoid hazards to children, account all parts and properly dispose of all packaging materials.
- If there are any installation questions, contact us at <http://www.dslightingus.com>