

PROCEDURE

This product must be installed in accordance with the applicable installation code by a person familiar with the construction and operation of the product and the hazards involved. Do not install insulation within 3" of fixture sides or wiring compartment, nor above fixture in such a manner to entrap heat.

1. Make sure that you have a solid ground preferably concrete. Make 4 holes for the ground anchor screws. (Not supplied in carton content) , maximum diameter of the screws Ø 0.39 inch.

Connect the supply voltage with the input leads of the driver. (Black/Black) and (White/White).
Connect the ground wire, which is attached to the housing.

2. Insert the housing on the floor fixture. Set and tighten the 4 screws on all sides.
ATTENTION: Carefully, place all the wiring into the housing.

phillips screwdriver
ca. PH 2



- **Damp and Wet** Location Listed
- **CSAus** Certified

IMPORTANT SAFETY INSTRUCTIONS:

- READ all the instructions before installation. Save instructions for later use.
- MIN 60°C SUPPLY CONDUCTORS.
- Turn off power at fuse or circuit breaker box before installation or before doing any maintenance work.
- Product must be mounted in locations and at heights and in manner consistent with its intended use, and in compliance with National Electric Code and local codes. Use of accessory equipment is not recommended.
- Installing contrary to instructions may cause unsafe conditions.
- Warning: Risk of fire. Consult a qualified electrician before installation.
- To avoid hazards to children, account all parts and properly dispose of all packaging materials.
- If there are any installation questions, contact us at <http://www.dslightingus.com>

1.

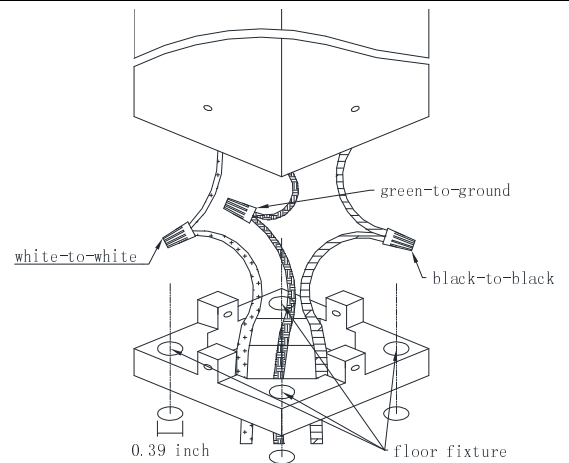

2.

