

PROCEDURE

This product must be installed in accordance with the applicable installation code by a person familiar with the construction and operation of the product and the hazards involved. Do not install insulation within 3" of fixture sides or wiring compartment, nor above fixture in such a manner to entrap heat.

1. Connect the primary leads from the junction box with the input leads of the driver. (Black/Black) and (White/White). Connect the ground wire, which is attached to the junction plate (Green-to-Ground). Screw the junction plate on the 4" junction box. Then, mount the square metal frame of the Secret lamp on the junction plate at the wall.
2. Connect the two driver wires with the two luminaire wires. ATTENTION! Take care of the polarity (+/+) (-/-). Insert the Secret lamp on the square metal frame. Set and tighten the Allen screws (2 mm) on both sides. ATTENTION: Carefully, place all the wiring into the junction box.
3. Fit the housing on the lamp.
4. Final result.

- Necessary installation equipment and screws:

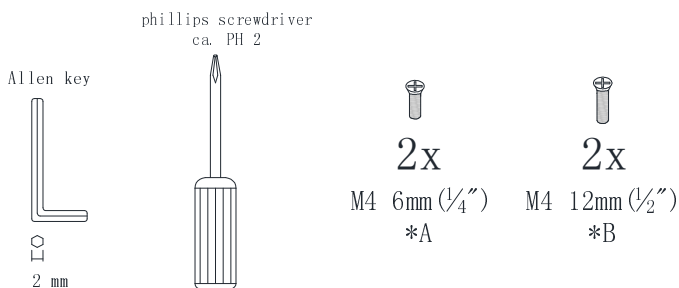

- **Damp and Wet Location Listed**
- **CSAus Certified**

IMPORTANT SAFETY INSTRUCTIONS:

- READ all the instructions before installation. Save instructions for later use.
- MIN 60°C SUPPLY CONDUCTORS.
- Turn off power at fuse or circuit breaker box before installation or before doing any maintenance work.
- Product must be mounted in locations and at heights and in manner consistent with its intended use, and in compliance with National Electric Code and local codes. Use of accessory equipment is not recommended.
- Installing contrary to instructions may cause unsafe conditions.
- Warning: Risk of fire. Consult a qualified electrician before installation.
- To avoid hazards to children, account all parts and properly dispose of all packaging materials.
- If there are any installation questions, contact us at <http://www.dislightingus.com>

1.

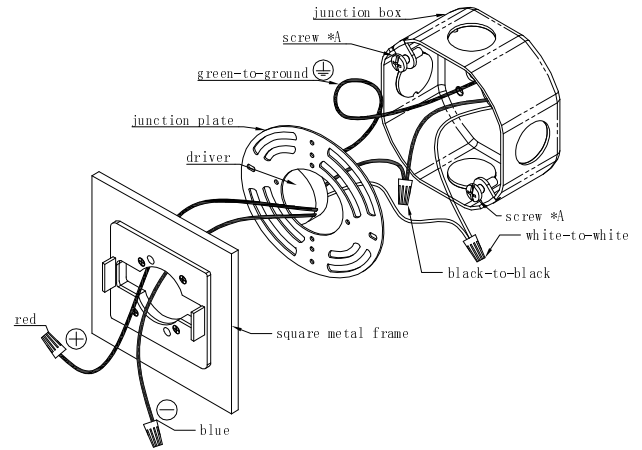

2.

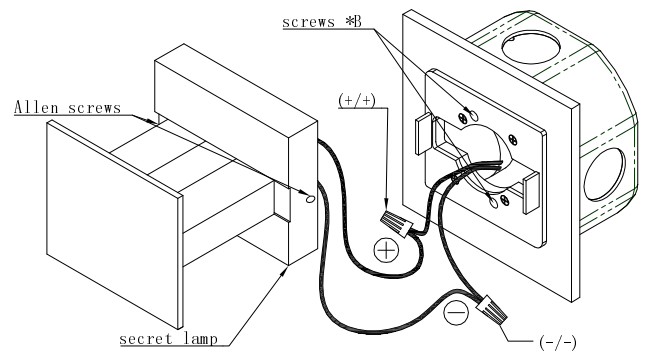

3.

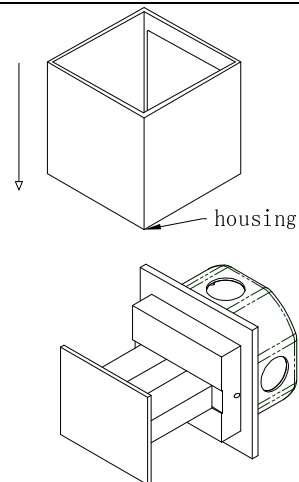

4.

